

Table I. (Continued)

Press., atm	Mole fraction, ethylene	Molar vol, ml/g-mol
	75°C	
5.00	0.065	230.7
10.00	0.120	221.7
15.00	0.170	213.7
20.00	0.220	205.3
25.00	0.265	198.0
30.00	0.310	190.8
35.00	0.353	183.7
40.00	0.395	177.0
45.00	0.435	170.5
50.00	0.475	164.0
55.00	0.510	158.2
60.00	0.542	152.8
65.00	0.575	147.2
70.00	0.602	142.5
75.00	0.632	137.2
80.00	0.660	132.7
85.00	0.685	128.2
90.00	0.712	123.5

bubble point isotherms were determined in the temperature range, 10–75°C. Each isotherm was obtained by several experimental runs to ensure reasonably good reproducibility. The average deviations of the experimental bubble points were ± 0.10 atm, ± 0.005 mole fraction of ethylene; for the liquid molar volume, it was ± 1.0 ml/g-mol. Since the vapor pressure of *n*-dodecane is low (4.2 mm of Hg at 75°C), the vapor phase is virtually pure ethylene at all the temperatures and pressures studied. Extensive computations on the maximum amount of *n*-dodecane which could be in the gas phase generally showed that the mole fraction of *n*-dodecane in the gas phase was less than 0.002 mole fraction at pressures above 5 atm. Thus dew point isotherms were not measured.

The fugacities of ethylene in the liquid mixtures were treated computationally in the same manner as reported by Lee and Kohn (6) for the ethane-*n*-dodecane system. The smoothed composition data were fitted to both the Scatchard modification of regular solution theory (11) and the Flory-Huggins solution model (1-3). The characteristic energy parameters (ΔU_{12}) in both models were found to be approximately temperature

Table II. Partial Molar Volumes at Infinite Dilution of Ethylene

Temp, °C	(Ml./g-mol)	
	Ethylene	<i>n</i> -Dodecane
10.0	61.0	223.0
25.0	63.5	227.0
50.0	68.0	234.0
75.0	71.8	240.5

independent in the temperature range studied. The energy parameter is 961 ± 34 cal/g-mol for the Flory-Huggins model and 469 ± 30 cal/g-mol for the Scatchard model. The standard deviation of the calculated ethylene fugacities from the 58 smoothed experimental values is 0.66 atm for the Flory-Huggins model and 1.22 atm for the Scatchard model.

Partial molar volumes of each of the components at infinite dilution of ethylene are tabulated in Table II. The partial molar volumes at each temperature are independent of composition within a few percent over the composition range covered in this study.

LITERATURE CITED

- (1) Flory, P. J., *J. Chem. Phys.*, **9**, 660 (1941).
- (2) Flory, P. J., *ibid.*, **10**, 51 (1942).
- (3) Huggins, M. L., *Ann. N.Y. Acad. Sci.*, **43**, 1 (1942).
- (4) "International Critical Tables," III, p 14, McGraw-Hill, New York, NY, 1928.
- (5) *Ibid.*, p 29.
- (6) Lee, K. H., Kohn, J. P., *J. Chem. Eng. Data*, **14**, 292 (1969).
- (7) McIntosh, R. L., Dacey, J. R., Maase, O., *Can. J. Research*, **17B**, 241 (1939).
- (8) Miller, S. A., "Ethylene and its Industrial Derivatives," pp 190-208, Ernst Benn Ltd., 1959.
- (9) Naldrett, S. N., Maase, O., *Can. J. Research*, **18B**, 118 (1940).
- (10) Rossini, F. D., Pitzer, K. S., Arnet, R. N., Brown, R. M., Pimentel, G. C., "Selected Values of Physical and Thermodynamic Properties of Hydrocarbons and Related Compounds," pp 373-5, Carnegie Press, Pittsburgh, Pa., 1953.
- (11) Scatchard, G., *Chem. Rev.*, **8**, 321 (1931).

RECEIVED for review June 9, 1971. Accepted January 24, 1972. This work was part of a study supported by the National Science Foundation under Grant NSF GK-2308.

Liquid-Vapor Equilibria and Thermodynamics of Lithium-Tin System

ALBERT K. FISCHER¹ and STANLEY A. JOHNSON

Argonne National Laboratory, Chemical Engineering Division, 9700 South Cass Ave., Argonne, IL 60439

As part of our study of binary liquid-metal systems containing an alkali metal, we have investigated the lithium-tin system at 1200°C. Previously, we reported data for the sodium-bismuth (6) and the sodium-lead (5) systems.

EXPERIMENTAL

The transpiration apparatus for the 1200°C experiments is shown in Figure 1 and is integrated with a helium atmosphere

¹ To whom correspondence should be addressed.

glovebox. The liquid metal sample is held in a long tantalum can, 10, which rests inside the 3-in. stainless steel furnace well, 8. A gas-tight seal is provided between the furnace well and the glovebox floor, 6, by means of a flange and O-ring protected from overheating by means of cooling coils (not shown). A similar gas-tight seal is provided between the cover plate, 5, and the glovebox floor. Three openings penetrate the cover plate. Two of these bear Veeco brand demountable connectors which permit gas-tight positioning of the tantalum thermocouple well, 11, and of the tantalum quench tube, 7. The third opening is the carrier gas inlet, 4. An additional Veeco

Liquid-vapor equilibrium data for the molten lithium-tin system at 1200°C are reported. The measurements were made by the transpiration technique, except for the compositions 80 and 90 at. % lithium. For these, the boiling point method was used to measure total vapor pressure. The melt composition range from 10–90 at. % lithium was covered in steps of 10 at. %. Activities for lithium were calculated directly from the data, and activity coefficients for tin were obtained by a graphical Gibbs-Duhem integration.

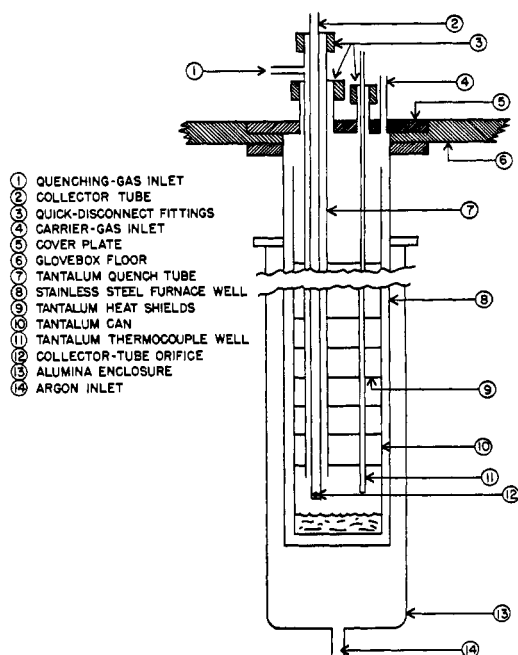

Figure 1. Transpiration apparatus for 1200°C study of the Li-Sn system

fitting is welded to the top of the quench tube; this fitting allows gas-tight positioning of the collector tube, 2, so that the orifice, 12, at the bottom of the collector tube is inside the quench tube. Since the furnace well, 8, is made of stainless steel, it is necessary to protect it from oxidation by air at 1200°C. For this purpose, an alumina tube, 13, is used to provide an argon-filled enclosure. Beneath the alumina tube is an alumina plate penetrated by an argon inlet and supported by a jack that presses the tube against a flange welded to the well. Silicone rubber gaskets provide an adequately tight seal at both ends of the alumina tube if they are kept cool with small fans. Tantalum heat shields, 9, inside the tantalum can, help maintain the sample region at a uniform temperature by reducing radiation losses and by eliminating gas movement by thermal circulation. Heat is supplied by a platinum-wound resistance furnace.

Inside the glovebox, there are three copper tubes for routing the argon carrier gas from the main supply to and through the transpiration apparatus, and out of the glovebox to the wet-test meter that measures the volume of gas used. While thermal equilibrium is being established at the beginning of an experiment, carrier gas enters the collector tube at the top, 2, and leaves through the inlet tube, 4. By this means, the collector tube is kept free of spurious vapor and condensate. When sample collection is to begin, the gas flow path is changed so that argon enters at 4 and leaves at 2. The sample is condensed in the upper part of the collector tube, and the argon gas volume is measured by the wet test meter. To terminate an experiment, the gas is made to enter the quench tube at 1 and to leave at 4, while the collector tube is raised quickly to bring the orifice up inside the quench tube. By this means,

the orifice is brought into a cool region while gas streams over the orifice, but not through it. No evidence was found for loss of collected sample by running down inside the tube and out the orifice.

In the experiments with liquids of 70 or more at. % tin, BeO crucibles rather than the tantalum cans were used to contain the samples. This helped to minimize liquid-metal creepage problems. For lithium-richer liquids, BeO crucibles could not be used because lithium corrodes BeO. In these cases, all parts (except the stainless steel collector tube) that were exposed to lithium vapor or liquid were made of tantalum. Care was taken to align the components to avoid contacts that might be creepage paths.

In the early phases of this work, efforts to economize by using stainless steel for the heat shields, thermocouple well, and quench tube showed that at points where the steel, tantalum, and lithium were in mutual contact, severe and rapid corrosion of all solid components occurred. Stainless steel was retained for the collector tube so that the condensed samples could be removed by washing with hydrochloric acid; this allowed us to recover traces of lithium that might have penetrated the grain structure. Lithium that had condensed on the upper exterior surface of the collector tube was removed, in the glovebox, by grinding it off with emery cloth. The whole exterior of the tube was then polished with steel wool before the condensate inside the tube was removed chemically.

In cleaning lithium from tantalumware, water could not be used because, even at room temperature, the evolved hydrogen caused severe hydrogen embrittlement of the tantalum; even gentle tapping of the embrittled tantalum resulted in fracture. Instead, lithium was removed by first melting and pouring out the bulk of the Li-Sn alloy (in the helium atmosphere glovebox), and then amalgamating the residual lithium in excess mercury. Finally, a nitric acid rinse removed traces of mercury.

The effect on the melt composition caused by the retention of lithium as a condensate on the surfaces above the melt was checked in some of the runs with 50 at. % Li-50 at. % Sn. The thin film of lithium deposited on the surfaces was recovered and determined. The deposited lithium accounted for a change of 0.5 at. % in the lithium content of the melt (i.e., from 50.0–49.5 at. % lithium). A proportionate amount was expected to be involved in the other melt compositions—somewhat more for lithium-richer compositions and somewhat less for the lithium-poorer compositions, because of the variation in the amount of vapor carried to the surfaces as the vapor density changes. Overall, it is reasonable to regard the melt compositions as being accurate within about 2% (relative) of the lithium content. All lithium analyses were done by flame photometry.

For melts having 80 and 90 at. % lithium, the lithium vapor pressure was so high that transpiration experiments at 1200°C were too short to measure the carrier gas volume accurately. For these two melt compositions, the transpiration apparatus was adapted to measure the total vapor pressure by the boiling point method. A larger (5-in.) furnace well was used, and the bottom 3 in. of the tantalum can was surrounded with an auxiliary heater. This heater consisted of four concentric alumina tubes, the innermost of which was slotted and wound with tantalum wire. Alumina spaghetti insulated the heater wire from the can. The can contained the sample to a depth

of about 2 in., thereby accommodating 4-5 gram atoms of lithium and tin. The heater leads passed through the well wall via insulated vacuum-tight fittings. The heat shields were retained, but the quench tube contained a tantalum paddle stirrer which could be rotated through the vacuum-tight fitting at the top. A temperature of about 800°C was maintained at the bottom of the 5-in. well with an external Ni-chrome-wound furnace.

The auxiliary heater inside the well heated the sample up to the 1200°C region. In this way, the 5-in. stainless steel well was kept cool enough so as not to suffer severe air oxidation or to soften and then collapse under reduced pressure. A tantalum thermocouple well (with a Pt-Pt/10% Rh thermocouple) measured the temperature of the melt close to the vapor interface. Pressure measurements were made with a Texas Instruments Fused Quartz Precision Pressure Gauge. In an experiment, the temperature of the melt was allowed to come to equilibrium at about 1200°C. Then, the pressure was reduced until the melt temperature started to drop. At this time the melt was stirred and the temperature allowed to become steady. Temperature and pressure were recorded. Another pressure reduction was made and the process of stirring was repeated. The pressures and boiling temperatures obtained this way were plotted as $\log P$ vs. $1/T$ curves and the total pressure at 1200°C was obtained graphically.

The precision of all the vapor pressure determinations is estimated to be 6% for the average deviation from the mean. Details of technique not covered here may be found in our earlier papers on liquid-metal systems (5, 6).

RESULTS

The results from the experiments are presented in Table I. The vapor pressure of tin over the melts was so low that the analysis for tin in condensed vapor samples was difficult and gave erratic results. However, the results confirmed the preponderance of lithium in the vapor and thus supported the decision to abandon further attempts to determine tin in the vapor. We then regarded the vapor as essentially pure lithium for the purpose of computing the activity of lithium in the melt. It was assumed that Li-Sn compound species were absent from the vapor. The corresponding assumption was made for the Na-Bi system, with some justification (6). For the Li-Sn system, the roughly similar activity coefficients tend to support the assumption. The activity coefficients, activities, and partial pressures of tin were calculated by means of a Gibbs-Duhem integration.

In computing the partial pressures of monatomic and di-

atomic lithium from the measured vapor densities or total pressures, a value of 2.887 was taken for the equilibrium constant for the gas phase equilibrium, $\text{Li}_2(\text{g}) \rightleftharpoons 2\text{Li}(\text{g})$, at 1200°C. The constant was evaluated from the data of Douglas et al. (3). The computation followed the procedure outlined previously (6). The paper by Douglas et al. presents data in convenient form for both the total vapor pressure of lithium and the partial pressure of Li_2 from room temperature to 1079°C. These data were extrapolated graphically by means of a $\log P$ vs. $1/T$ plot to 1200°C, thereby yielding values of 275 torr and 30.5 torr for P° (total vapor pressure over pure lithium) and $p^\circ_{\text{Li}_2}$ (partial pressure of diatomic lithium over pure liquid lithium), respectively. Accordingly, a value of 244 torr for p°_{Li} (partial pressure of monatomic lithium over pure liquid lithium) was obtained. The total pressure derived from Douglas et al. agrees well in the 1200°C region with the recent data reported Achener and Fisher (1). The experimental values of Achener and Fisher were plotted as $\log P$ vs. $1/T$, and an interpolated value of 277 torr at 1200°C was obtained for P° . However, the values obtained from Douglas et al. and from Achener and Fisher are about 5% higher than the ones calculated from the equations in the reports by Rigney et al. (10) and by Bohdansky and Schins (2), namely, 261 and 263 torr, respectively. The selection of the Douglas data was reinforced also by the agreement between Douglas' results and a measurement of P°_{Li} we had performed earlier. At 932°C (1205K) we had found a value of P°_{Li} of 17.4 torr by the quasistatic method (4); the data of Douglas et al. yield a value of 17.6 torr.

For the purpose of calculating the partial pressure of tin from the activity coefficients obtained from the Gibbs-Duhem integration, a value of P°_{Sn} of 5.1×10^{-3} torr at 1200°C (1473K) was derived from the data in Hultgren et al. (9).

The total vapor pressure values are shown as a pressure-composition phase diagram in Figure 2. The diagram is unusual in appearance because of the need to use a logarithmic scale to plot the vapor composition so that the vapor does not appear as a line congruent with the axes. The greater than three orders of magnitude range in pressure also is best represented logarithmically. The activity coefficients are shown in Figure 3.

DISCUSSION

A noteworthy feature of both Figures 2 and 3 is the bend in the curves that occurs at about 30 at. % lithium in the liquid. In the solid phase, the compound LiSn_2 is probably known (8). However, LiSn_2 disappears above the peritectic temperature of 326°C and our data were taken at 874° higher. It is tempting

Table I. Experimental Data for Lithium and Calculated Results for Tin in Lithium-Tin System at 1200°C

Atom fraction lithium in liquid	Total lithium vapor pressure, torr ^a	Monatomic lithium vapor pressure, torr	Activity of lithium	Activity coeff of lithium	Activity coeff of tin ^b	Activity of tin ^b	Vapor pressure of tin, torr ^b
0.100	0.266	0.266	1.09×10^{-3}	0.0109	0.994	0.895	4.56×10^{-3}
0.200	0.705	0.705	2.89×10^{-3}	0.0144	0.947	0.758	3.86×10^{-3}
0.296	1.62	1.62	6.63×10^{-3}	0.0223	0.817	0.574	2.93×10^{-3}
0.300	2.41	2.41	9.87×10^{-3}	0.0328	0.695	0.486	2.48×10^{-3}
0.400	4.84	4.83	0.0198	0.0496	0.553	0.332	1.69×10^{-3}
0.500	9.2	9.2	0.0377	0.0754	0.388	0.194	9.89×10^{-4}
0.600	19.1	18.9	0.0775	0.129	0.195	0.0780	3.98×10^{-4}
0.700	46.2	45.3	0.186	0.266	0.0517	0.0155	7.91×10^{-5}
0.800	90.0	86.6	0.354	0.442	0.0108	0.00216	1.10×10^{-5}
0.900	195	180	0.739	0.821	2.57×10^{-4}	2.57×10^{-5}	1.31×10^{-7}

^a Measurements were made by the transpiration technique except for liquid compositions N_{Li} equals 0.800 and 0.900 where the boiling point method was used. Beryllium oxide crucibles were used as containers for samples containing 70 or more at. % tin. Tantalum vessels were used for lithium-rich melts. For compositions of 70 at. % tin, the lithium activity was reduced enough so that the BeO crucibles emerged from the experiments with only a gray film on the inside surface. Tin-rich melts yielded clean BeO crucibles. It did not appear likely that the gray film would have had a significant effect on the activity of lithium. ^b These values were calculated from the Gibbs-Duhem integration.

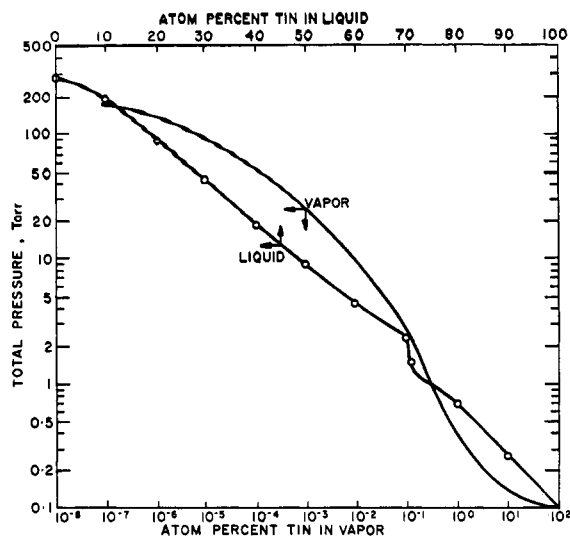

Figure 2. Pressure-composition diagram for Li-Sn system at 1200°C

See footnote in Table I for information on crucible materials

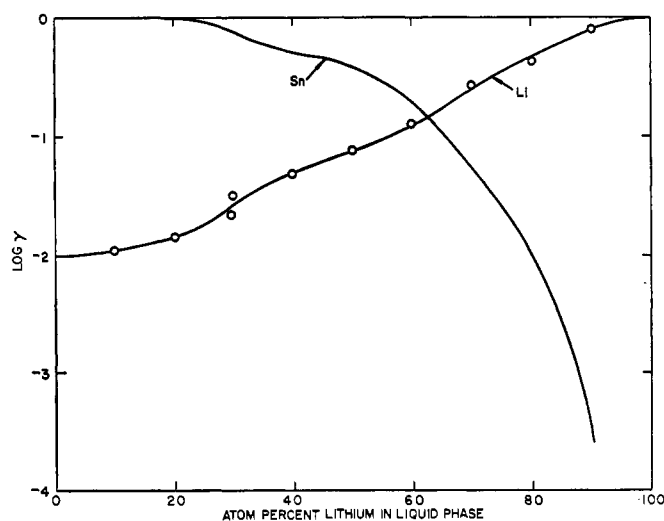

Figure 3. Activity coefficient-composition diagram for Li-Sn system at 1200°C

to ascribe the inflectional nature of the curves to residual effects of the attractive forces that led to the formation of LiSn_2 in the solid. Such a procedure was followed in our study of the Na-Bi system where similar inflections were seen. However, in the present case, even more pronounced inflections would be expected in the 75-80 at. % lithium region in which a number of compounds exist in the solid, the highest (congruently) melting

one being Li_7Sn_2 with a melting point of 783°C. In this region, our data were taken at only 417°C above the melting point of Li_7Sn_2 , but the shapes of the curves show only slight signs of residual attractive forces. If residual compound-like species and the associated attractive forces are to be invoked, then, possibly, in this region, the variety of compounds presumed to exist in the solid from $\text{Li}_{22}\text{Sn}_5$ (81.3 a/o Li) to Li_2Sn (66.7 a/o Li) results in a smearing out of the effect reflected in relatively smooth pressure and activity coefficient curves.

If a quasi-ideal solution treatment is contemplated, the situation here is about as unpropitious as for the Na-Pb system (5). Aside from the fundamental, unsettled general question of whether compound-like species exist in a liquid-metal melt, there is also uncertainty in the present case as to what the compounds are in the solid state. Hansen and Anderko (8) in their discussion of the Li-Sn system state that it would be valuable to corroborate by X-ray analysis the existence and formulas of the six intermediate phases, Li_4Sn , Li_7Sn_2 , Li_5Sn_2 , Li_2Sn , LiSn , and LiSn_2 . An X-ray study bearing on one compound has appeared (?); " Li_4Sn " was claimed to be actually $\text{Li}_{22}\text{Sn}_5$. This element of controversy renders the selection of "compounds" for a quasi-ideal solution treatment hazardous. We will not attempt it, and we reaffirm our position expressed in the Na-Pb paper that such a treatment can only be applied meaningfully when it is shown by independent methods that molecule-like species of known stoichiometry exist in liquid-metal solutions.

ACKNOWLEDGMENT

We are grateful to E. J. Cairns for helpful discussions.

LITERATURE CITED

- (1) Achener, P. Y., Fisher, D. L., AGN-8191, Vol. 2, July 1967.
- (2) Bohdansky, J., Schins, H. E. J., *J. Phys. Chem.*, **71**, 215 (1967).
- (3) Douglas, T. B., Epstein, L. F., Dever, J. L., Howland, W. H., *J. Amer. Chem. Soc.*, **77**, 2144 (1955).
- (4) Fischer, A. K., *Rev. Sci. Instr.*, **37**, 717 (1966).
- (5) Fischer, A. K., Johnson, S. A., *J. Chem. Eng. Data*, **15**, 492 (1970).
- (6) Fischer, A. K., Johnson, S. A., Wood, S. E., *J. Phys. Chem.*, **71**, 146 (1967).
- (7) Gladyshevskii, E. I., Oleksiv, G. I., Kripyakevich, P. I., *Soviet Physics-Crystallography*, **9**, 269 (1964); transl from *Kristallografiya*, **9**, 338 (1964).
- (8) Hansen, M., Anderko, K., "Constitution of Binary Alloys," pp 903-4, McGraw-Hill, New York, NY, 1958.
- (9) Hultgren, R., Orr, R. L., Anderson, P. D., Kelley, K. K., "Selected Values of Thermodynamic Properties of Metals and Alloys," pp 843-4, Wiley, New York, NY, 1963.
- (10) Rigney, D. V., Kapelner, S. M., Cleary, R. E., TIM-844 (1965).

RECEIVED for review July 2, 1971. Accepted April 13, 1972. Work performed under auspices of the U. S. Atomic Energy Commission.